

# WHOLE HOUSE VENTILATORS PRODUCT MANUAL & INSTALLATION GUIDE



Serial Number \_\_\_\_\_

Date of Purchase \_\_\_\_\_

Point of Purchase \_\_\_\_\_

The serial number is located on the shipping carton and on a label affixed to the upper housing.

**Unpacking your HV:** When you have unpacked your HV carefully you will find the following:

**HV1000**

- One (1) HV1000 Whole House Ventilator
- One (1) White Metal Grille w/(6) Screws
- One (1) Electrical Box Cover w/(2) Screws
- Four (4) #8x3/4 Screws
- One (1) Grounding Screw (green)

**HV1600**

- One (1) HV1600 Whole House Ventilator
- One (1) White Metal Grille w/(6) Screws
- Four (4) #8x3/4 Screws
- One (1) Hand Held Remote Transmitter

**The Best Location for your HV:** The HV should be installed in your attic in a central location within your home. Above a central hallway or at the top of a stairwell will provide the best airflow. The fan can be mounted vertically.

- ▶ Make sure that there aren't any pipes, wires, rafters, air conditioning or heating ducts running through the space where the HV will be installed and that the doors will open into an unoccupied area.
- ▶ Make sure that you have adequate exhaust area out of your attic. This can be accomplished with a combination of roof, ridge or gable end vents. The HV1000 requires a minimum of 3 square feet and the HV1600 requires a minimum of 5 square feet of attic exhaust area.
- ▶ Make sure that there is a minimum of 12" clearance above the fan for the doors to open. Another 12" above the open doors will be needed to prevent a back pressure on the fans.
- ▶ If your home has an engineered roofing system, care should be taken that the HV will fit within the truss layout.

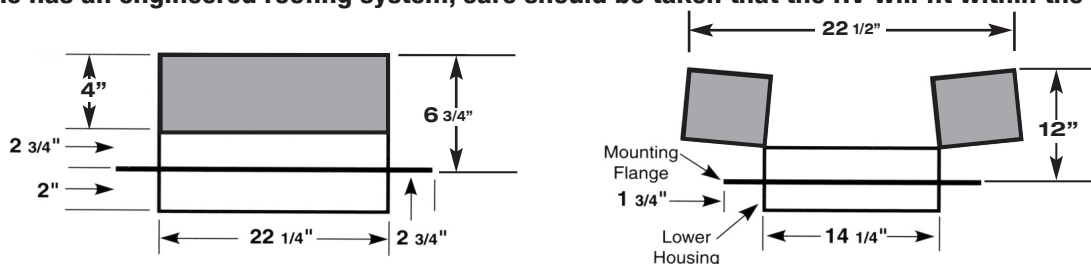

**READ AND SAVE THESE INSTRUCTIONS**

- ⚠ WARNING:** TO REDUCE THE RISK OF FIRE, ELECTRIC SHOCK, OR INJURY TO PERSONS, OBSERVE THE FOLLOWING:
- ✔ Use this unit in the manner intended by the manufacturer. If you have any questions, contact the manufacturer.
  - ✔ Before servicing or cleaning unit, switch power off at service panel and lock service panel to prevent power from being switched on accidentally. When the service disconnecting cannot be locked, securely fasten a prominent warning device, such as a tag, to the service panel.
  - ✔ When cutting or drilling into wall or ceiling, do not damage electrical wiring or other hidden utilities.
  - ✔ Never place a switch where it can be reached from a tub or shower.
  - ✔ Do not use this fan over a tub or shower.
  - ✔ Do not use this fan over cooking appliances.

✔ **WARNING:** To Reduce The Risk of Fire or Electric Shock, Do Not Use This Fan With Any Solid-State Speed Control Device.

**CAUTION:** For General Ventilation Use Only. Do Not Use To Exhaust Hazardous Or Explosive Materials And Vapors

**CAUTION:** This unit has an unguarded impeller. Do Not Use in Locations Readily Accessible to People or Animals.

LIKE US ON FACEBOOK



FOLLOW US ON TWITTER



320 Main Street • Buzzards Bay, MA 02532  
508-759-4660 / 800-222-5932 / Fax 508-759-6001

## Installation

### Tools and supplies needed (Not Included):

You will need the following items: two pieces of 2x stock to match your existing framing, a saw to cut the hole in the ceiling, a hammer or screw gun to attach the blocking to the existing joists, a phillips head screw driver to attach the grille, weather strip material and low expansion spray foam sealant. For the HV1000, a single pole, single throw (SPST) wall switch will be needed.

1. The fan housing will fit either 16" or 24" on center framing. Cut two pieces of 2x stock (2 x 6 or 2 x 8 etc.) of the same dimension as the existing joists. Add these pieces of framing to form a box between the joists. (Figure 1).

*TIP: When the HV is to be installed in a hallway or other location with low ceilings, some homeowners find that building a box out of 2 x 10s or similar material will raise the HV to a position where the sound level will be reduced but the efficiency of the fans will not be diminished. This box should not exceed 12 inches in height.*

2. Cut a hole in the ceiling under where the HV will be installed. The hole should be no larger than 14 1/2" x 22 1/2". This will allow for the grille to cover the exposed edges. The suggested method for making the proper sized hole in the ceiling is; cut a pilot hole under where the fan will be installed. (Figure 2) From above, using a saw, cut along the inside edge of the framework removing the ceiling panel and any strapping within the frame. **Do not damage electrical wiring or other hidden utilities.**

3. Install a foam weather stripping or other flexible material (not supplied) on the top of the joists and added framing. This gasket will serve to seal between the housing and the framing as well as dampen vibrations. Check the joint between the ceiling and the 2x stock. Some types of ceilings are spaced away from the joists. Any gap between the 2x's and the ceiling should be sealed prior to final installation. (Figure 3) Use a low expansion spray foam sealant (not supplied).

4. Set the HV on the gasket with the doors facing to open into the attic. The lower housing will fit into the box with the mounting flanges overlapping the joists. (Figure 4) **The HV should not be forced into this opening.** Forcing it into place may cause the doors to bind and not function properly.

5. If desired, secure the HV to the top of the joists using the #8x3/4 screws provided. When fastening the mounting flange to the joists care should be taken that all screws are tightened evenly to avoid the door hinges binding. **DO NOT OVER TIGHTEN.**

6. Wire the HV as shown in the Wiring section of this manual. It is recommended that the wiring of the HV be done by a licensed electrician.

7. Check the HV for proper operation. Turn the unit on and allow 30 seconds for the doors to fully cycle open and the fans to start. **DO NOT FORCE THE DOORS OPEN.**

8. Install the grille (6 screws included) on the ceiling below the fan (Figure 5).

*TIP: Some owners find the installation has a more finished look when the inside of the blocking has been painted before the unit is installed and the grille is put in place.*

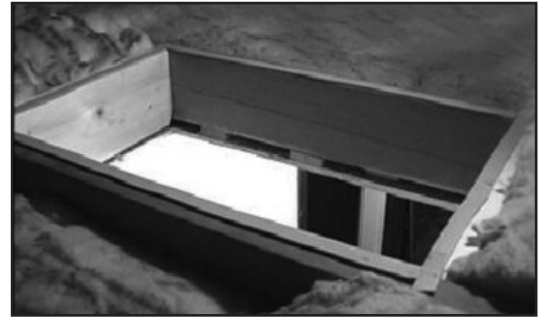

Figure 1.

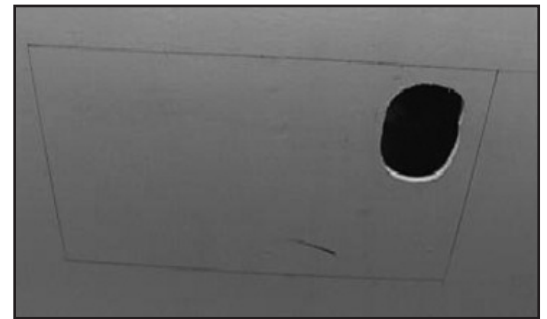

Figure 2.



Figure 3.

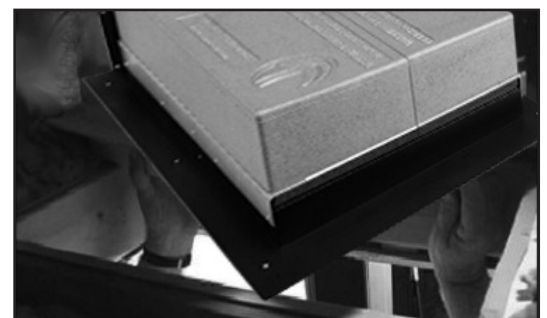

Figure 4.



Figure 5.

## Specifications

Voltage .....	115VAC 60 Hz
Power	
HV1000 .....	70 Watts
HV1600 High .....	230 Watts
HV1600 Low .....	207 Watts
Airflow @ .03" (System)	
HV1000 .....	1150 CFM
HV1600 High .....	1600 CFM
HV1600 Low .....	1150 CFM

R-Value	
HV1000 & HV1600 .....	R-38
Weight	
HV1000 .....	17 Lbs.
HV1600 .....	21 Lbs.
Rough Opening .....	14 1/2" x 22 1/2"
Grille Dimensions .....	15 3/4" x 25 3/4"
Grille Color .....	White

## Wiring

**Important** - Wiring the HV is different than a normal ON/OFF fan. Because the doors are motorized, they need power to open and power to close. The HV requires a constant source of power. The fan operation is controlled internally. Please follow the instructions carefully. It is recommended that the wiring of the HV be done by a licensed electrician.

### Be sure to turn off power before wiring the HV Whole House Fan

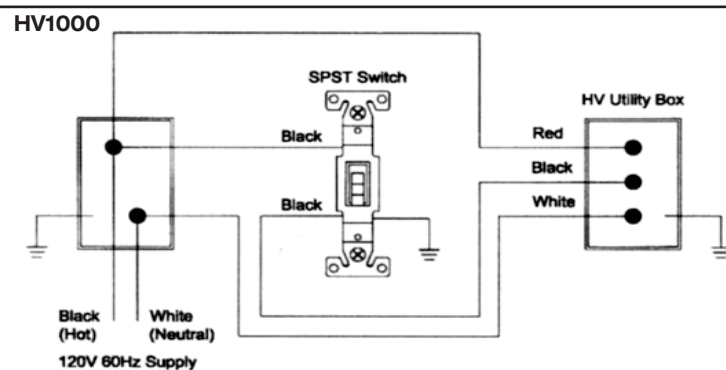

The HV whole house cooling fans are not for use with solid state speed controls

Hardwiring the unit to wall switches using the BLUE and YELLOW wires will provide additional, manual control. Using these switches will override the remote control function. The line cord must remain plugged into a constant HOT outlet.

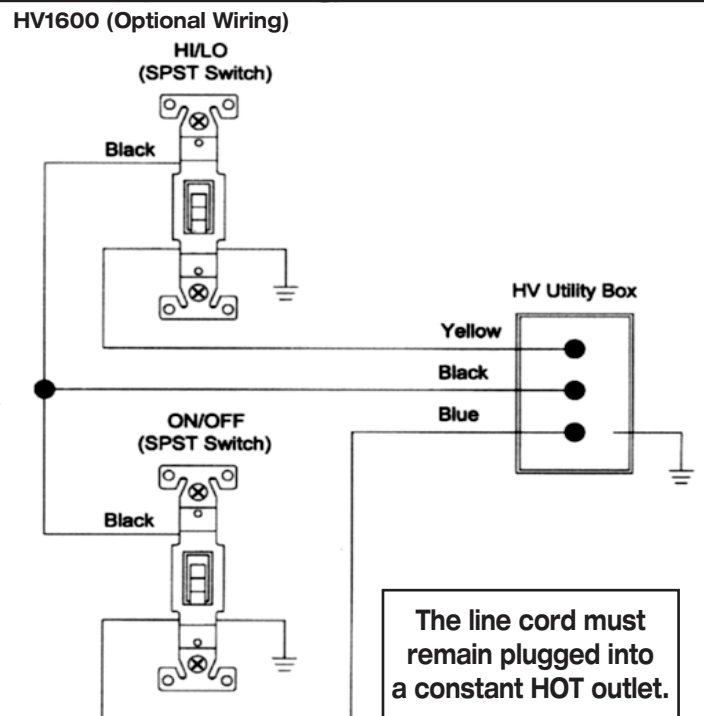

The line cord must remain plugged into a constant HOT outlet.

## Operating your HV

**Important** - Be sure at least one window is open when the fan is operating.

**HV1000** - The HV1000 is operated by the wall switch (not included) installed per the wiring instructions. An optional remote control kit is available (Part# TTI-HVRC).

The remote transmitter has a single button. One press and the HV1000 will start. A second press will stop the HV1000.

**HV1600** - The HV1600 is controlled by the hand held remote transmitter. Additional controls, when used, may override the remote control. See the Wiring section of this manual for further details.

The remote transmitter has two buttons. Button 1 is for ON/OFF. One press of button 1 and the HV1600 will start. A second press of button 1 will stop the HV1600. Button 2 is for LO/HI speed. A press of button 2 will change the speed.

## Care

All the motors in the HV are permanently sealed and do not require oiling. To keep dirt, dust and debris from the fans we recommend that you periodically remove the grille from within the living space and dust the fan blades. Please remember to make sure that the fan is OFF before dusting the fan blades.

## Troubleshooting

**HV1000:** The most common problem with the HV1000 is caused by incorrect wiring. Before you check anything else make sure: WHITE wire in HV1000 is connected to 115 VAC Line Neutral; RED wire in HV1000 is connected to 115 VAC Line Hot (Constant Hot Feed); BLACK wire in HV1000 is connected to a switch that will make it hot when the switch is closed.

**HV1600:** If the wireless remote fails to activate the fan, the battery may need replacing. The Skytech transmitter (older models) uses a type A23/12V battery. The SECO transmitter (newer models) uses (2) CR2016 batteries. Remove the back plate from the transmitter and remove the battery. Following the markings, replace the battery. Secure the back plate to the transmitter.

## Re-programming the HV1600 Remote

- Remove the cover from the control box
- Push the **Brown #1** button on the side of receiver for 3 seconds...the Green LED light will flash quickly
- While the Green LED is flashing push the **"1"** button on the transmitter... the Green LED light will flash... this programs ON/OFF
- Push the **Red #2** on the side of the receiver for 3 seconds...the Red LED light will flash quickly
- While the Red LED is flashing push the **"2"** button on the transmitter... the Red LED light will flash... this programs HI/LO
- Replace the cover on the control box

Switch	Doors	Fans	Possible Cause	Try
On	Do Not Open	Do Not Run	No Power	Check connections and circuit breakers
On (audible "click")	Do Not Open	Do Not Run	No constant power on Red	Check wiring connections. There must be constant power on the red wire.
Off	Do Not Close	Stop	RED and BLACK are connected together.	Check wiring connections. Connections at the fan must be made individually.
On	Both Open	One Fan Runs	Something blocking fan rotation	Turn the power off and check for foreign matter blocking blade rotation.
On	Both Open - One closes then opens...	One Fan Runs	Door motor gears or switch may have been stressed during installation. Framing opening may be too small.	Remove fan from between joists and test operation while fan is sitting on top of joists. If the fan operates, enlarge the opening and return the fan to installed position.
Off	Both Closed - One opens then closes...	Stop	Door motor gears or switch may have been stressed during installation. Framing opening may be too small.	Remove fan from between joists and test operation while fan is sitting on top of joists. If the fan operates, enlarge the opening and return the fan to installed position

*If for some reason the lift arm becomes detached from the door bracket it can easily be re-attached. Inspect the pin for damage and replace if necessary. Cycle the whole house fan until the doors are in the open position. Support the door and simply push the lift arm over the tapered end of the pin.*

**LIMITED WARRANTY** If, within the period of three years from the date of purchase, the HV 1000 or HV 1600 (the Product) is defective or malfunctions in normal home use, Tamarack Technologies, Inc. will repair or replace the Product, at its discretion. Customer is responsible for shipping charges. NOTE: Some states codes require fans to be hardwired. Hardwiring of the HV1600 will not void warranty provided the wiring is performed by a licensed electrician.

**CONDITIONS, EXCLUSIONS, AND LIMITATIONS** -This Warranty is subject to the following conditions, exclusions and limitations: THIS WARRANTY DOES NOT COVER PROBLEMS RESULTING FROM INSTALLATION, OPERATION OR MAINTENANCE THAT HAS BEEN UNDERTAKEN OTHER THAN IN ACCORDANCE WITH THE INSTRUCTIONS. THIS WARRANTY DOES NOT COVER PROBLEMS RESULTING FROM DEFECTS IN OR CAUSED BY ASSOCIATED EQUIPMENT (FURNACES, SOLARIA, ETC.); FROM REPAIRS OR MODIFICATIONS ATTEMPTED BY PERSONS OTHER THAN TAMARACK TECHNOLOGIES, INC.; FROM ABUSE, ACCIDENTAL OR SHIPPING DAMAGE OR ACTS OF GOD. THIS WARRANTY DOES NOT APPLY TO THE PRODUCT USED OUTSIDE THE UNITED STATES, ITS TERRITORIAL POSSESSIONS, AND CANADA. EXCEPT AS SET FORTH ABOVE, NO EXPRESS OR IMPLIED WARRANTY IS GIVEN OR AUTHORIZED BY TAMARACK TECHNOLOGIES, INC. AND ALL OTHER SUCH WARRANTIES ARE EXPRESSLY DISCLAIMED. ANY WARRANTY OR MERCHANTABILITY OF FITNESS FOR ANY PARTICULAR PURPOSE SHALL BE LIMITED TO THE WARRANTY HEREUNDER. MOREOVER, ANY LIABILITY OF TAMARACK TECHNOLOGIES, INC. FOR THE PRODUCT SHALL BE LIMITED TO THE REPLACEMENT VALUE OF THE PRODUCT. IN NO EVENT SHALL TAMARACK TECHNOLOGIES, INC. BE LIABLE FOR ANY INCIDENTAL DAMAGES OR FOR ANY CONSEQUENTIAL PROPERTY OR COMMERCIAL DAMAGES, IRRESPECTIVE OF THE CAUSE THEREOF, OCCURRING EITHER DURING OR AFTER THE WARRANTY PERIOD, INCLUDING WITHOUT LIMITATION ANY DAMAGES TO ANY PART OF A BUILDING OR ITS CONTENTS. NOTE: SOME STATES DO NOT ALLOW THE EXCLUSION OR LIMITATION OF INCIDENTAL OR CONSEQUENTIAL DAMAGES AND SOME STATES DO NOT ALLOW LIMITATIONS ON HOW LONG AN IMPLIED WARRANTY LASTS, SO THE ABOVE LIMITATIONS OR EXCLUSIONS MAY NOT APPLY TO YOU. THIS WARRANTY GIVES YOU SPECIFIC LEGAL RIGHTS AND YOU MAY ALSO HAVE OTHER RIGHTS THAT VARY FROM STATE TO STATE. **PROOF OF PURCHASE REQUIRED.**



320 Main Street • Buzzards Bay, MA 02532  
508-759-4660 / 800-222-5932 / Fax 508-759-6001